

# 落ちふた式U形側溝 (標準)

(例1-300A)

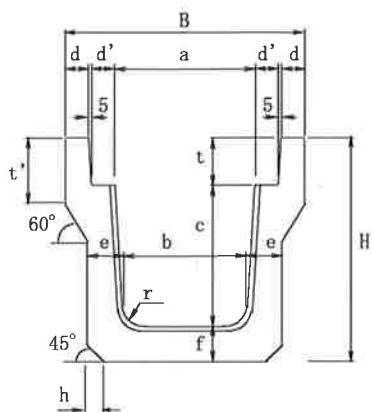

種類	略号	用途
1種	1	主として歩道に設置するもの

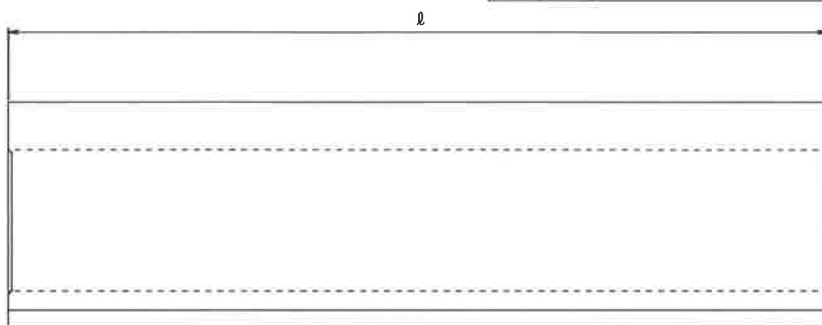

(例3-300A)

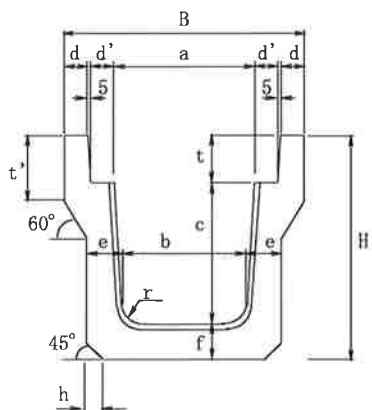

種類	略号	用途
3種	3	車両(後輪一輪500N以下)が隣接して走行することはまれで、走行することがあっても一時待避などで低速で走行するような場所に、車道に平行して設置するもの

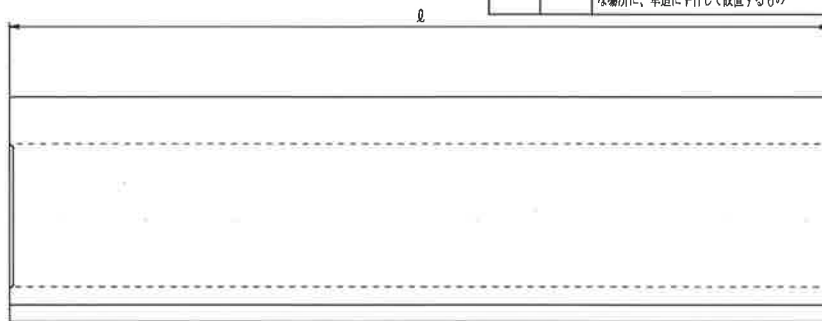

単位：mm

種類	呼び	寸法											l	B	H	参考重量	
		a	b	c	d	d'	e	f	h	t	t'	r					
1種	250	250	230	250	40	55	55	55	20	90	120	50	2000	450	395	294	
	300A	300	280	300			60	60		95				500	455	348	
3種	250	250	230	250	45	55	65	65	30	90	120	50	2000	460	405	338	
	300A	300	280	300	50		70	70	40	95	140			520	465	423	
	300B		270	400											520	565	480
	300C		260	500			80	80						520	675	588	
	400A	400	370	400	55		70	70		110				630	580	525	
	400B		360	500			80	80						630	690	637	
	500A	500	460		60	60				125	155			750	705	709	
	500B		450	600			90	90			175			750	815	851	
寸法の許容差		±3											±6				

# 落ちふた式U形側溝

(標準・防音・集水)

標準 例3-300A

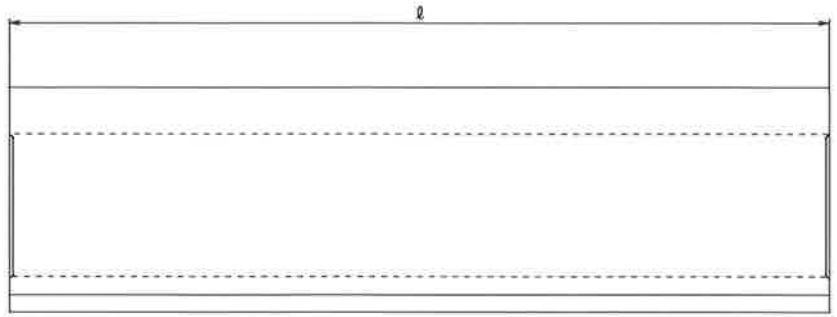
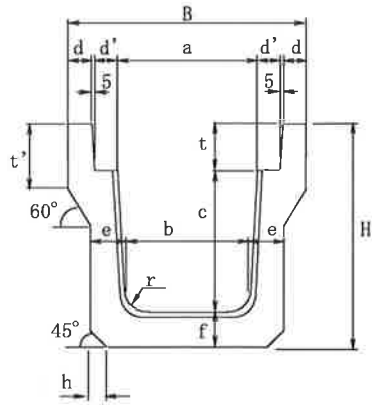

防音 例3-300A

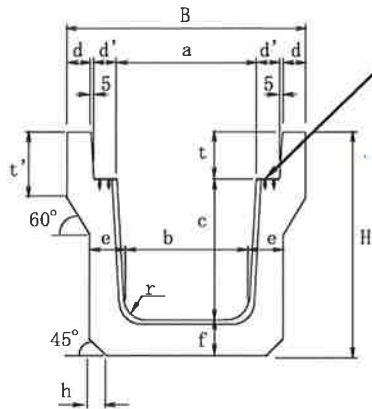

防音ゴム形状寸法

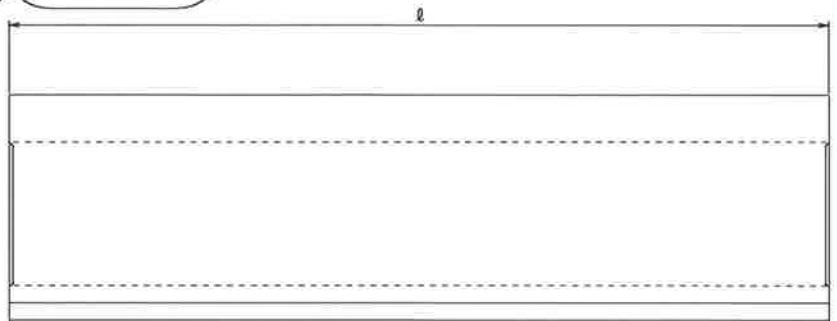
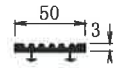

集水 例3-300A

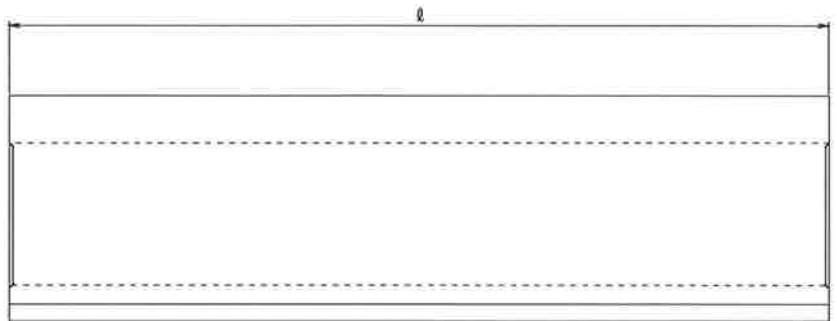
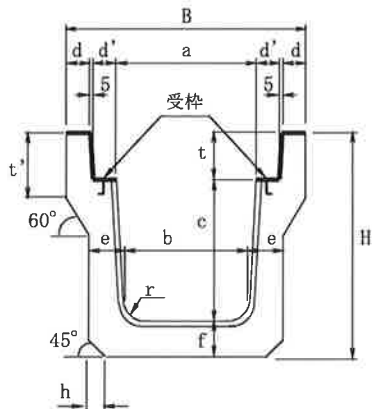

単位: mm

種類	呼び	寸法											L	B	H	参考重量
		a	b	c	d	d'	e	f	h	t	t'	r				
3種	250	250	230	250	45	55	65	65	30	90	120	50	2000	460	405	338
	300A	300	280	300	50	70	70	95		140						
	300B		270	400		40										
	300C		260	500			80	80								
	400A	400	370	400	55		70	70	110					630	580	525
	400B		360	500			80	80						630	690	637
	500A	500	460		60	60			125	155				750	705	709
	500B		450	600			90	90		175				750	815	851
寸法の許容差		±3											±6			

# 落ちふた式U形側溝 (排水ドレン金具仕様)

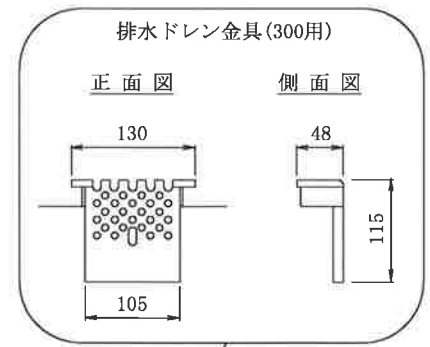

(例：3-300A)

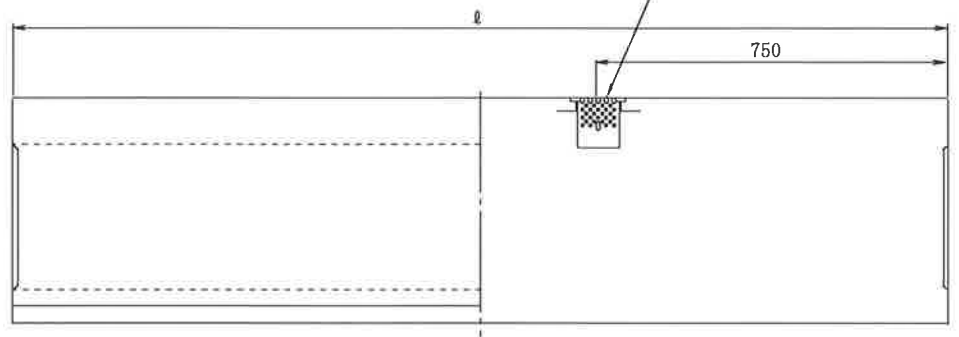
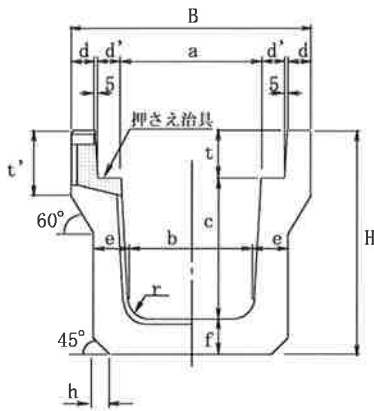

単位：mm

種類	呼び	寸法											参考重量			
		a	b	c	d	d'	e	f	h	t	t'	r				
1種	250	250	230	250	40	55	55	55	20	90	120	50	2000	450	395	294
	300A	300	280	300			60	60		95				500	455	348
3種	250	250	230	250	45	55	65	65	30	90	120	50	2000	460	405	338
	300A	300	280	300	50		70	70	40	95	140			520	465	423
	300B		270	400			80	80							520	565
	300C		260	500			80	80						520	675	588
	400A	400	370	400	55		70	70		110				630	580	525
	400B		360	500			80	80						630	690	637
	500A	500	460		60	60				125	155			750	705	709
	500B		450	600			90	90			175			750	815	851
寸法の許容差		±3											±6			

# 落ちふた式U形側溝 (ふた)

例 1-300

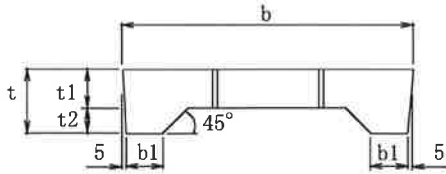

例 3-300

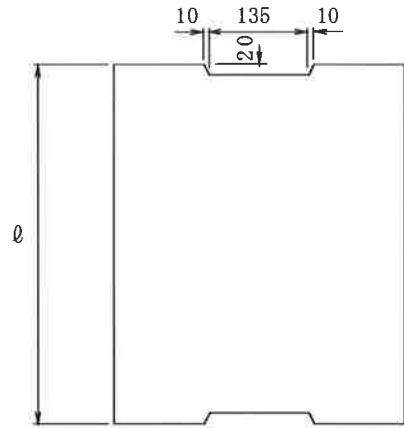
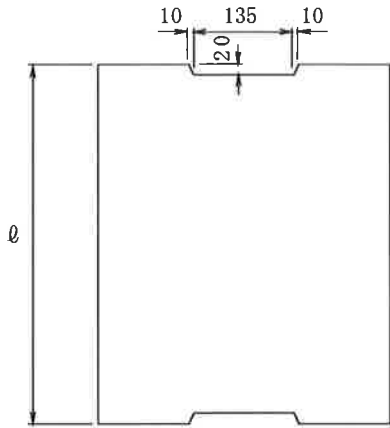
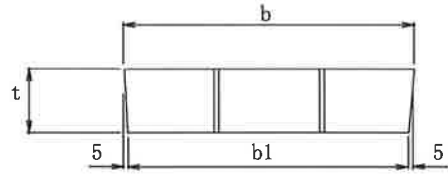

単位 : mm

種類	呼び	寸 法						参考重量
		b	b1	t	t1	t2	l	
1種	250	362	50	90	55	35	500	30
	300	412	51	95		40		34
3種	250	362	352	90	—	—	500	38
	300	412	402	95				46
	400	512	502	110				60
	500	622	612	125				92
寸法の許容差		±3						

## 落ちふた式U形側溝（片手ふた）

例 3-300

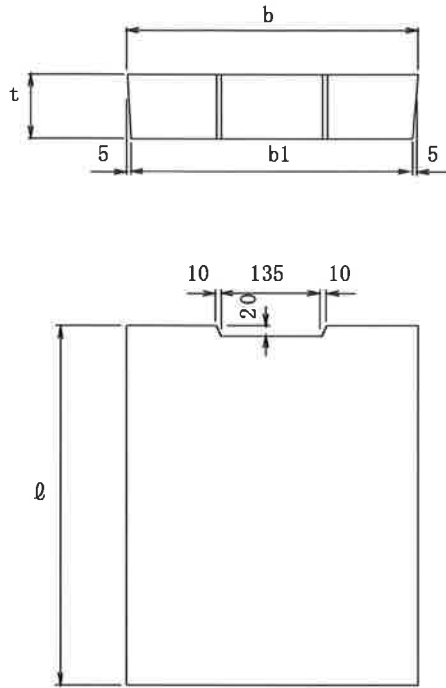

単位：mm

種類	呼び	寸 法				参考重量
		b	b1	t	ℓ	
3種	250	362	352	90	500	38
	300	412	402	95		46
	400	512	502	110		60
	500	622	612	125		92
寸法の許容差		± 3				